

CERTIFICATION



HACCP International



ISO9001

ICE MATE

by  HOSHIZAKI

SRM-200AB-14-B-301SA

ICE MAKER

HALF DICE

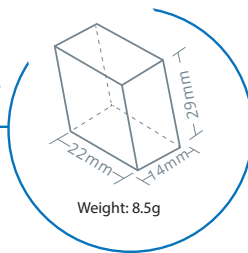

ICEMATE is committed to bringing high-efficiency / energy-saving, and high quality ice-making product to people who have dreams and desire to create their own business with the best scientific technology and manufacturing technology.

KEY FEATURES

SAFETY AND HYGIENE ASSURED ICE MACHINE

AUTO-CLEANING



Timely maintenance of water system can extend life of equipment.

PURE ICE



Overflow self-cleaning function, ensuring ice hygiene

IoT



Slow melt Dilution



Slow Dilution
Slower melting speed due to -7°C of inside temp of ice cube

Powerful Ice Making



Powerful Ice Making

Designed for commercial Ice Machine



Energy & Water Saving, Quiet Operation



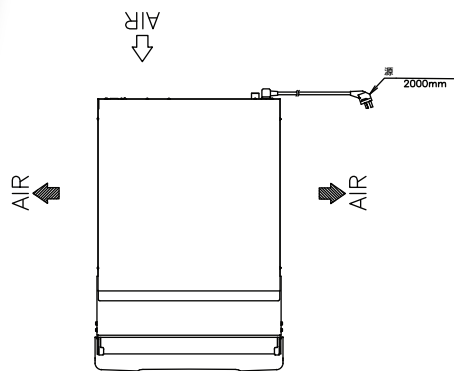

BIN TOP VIEW

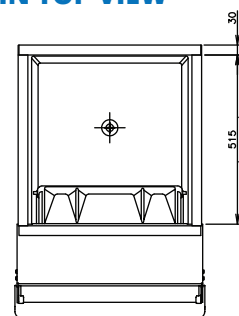

RIGHT SIDE

BACK SIDE

FRONT SIDE

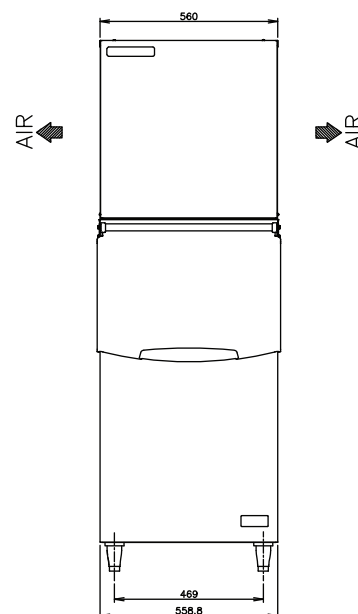
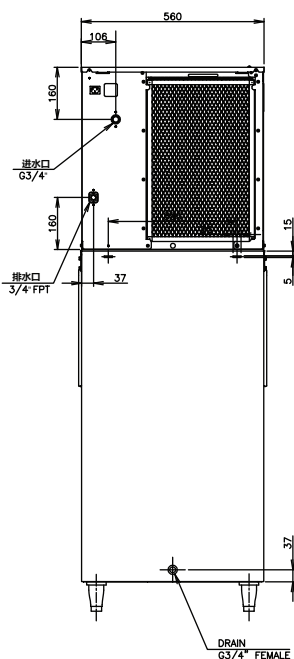
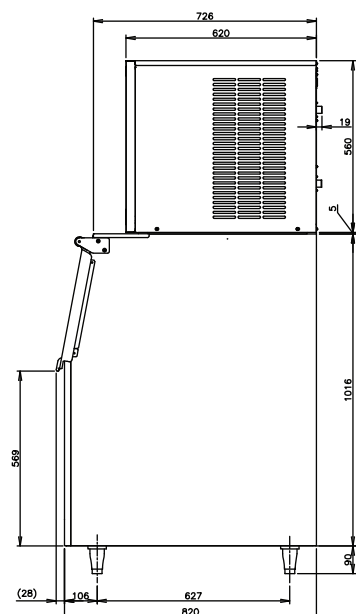

SPECIFICATIONS

Ice Dimensions (W x D x H)	29 x 14 x 22 mm
Outside Dimensions (W x D x H)	560 x 820 x 1671(~1701)mm
Package Dimensions (W x D x H)	Ice Maker: Pallet+Carton: 650 x 710 x 750mm Storage Bin: 655 x 924 x 1138mm
Weight (Net / Gross)	Ice Maker: 50kg / 66.5kg Storage Bin: 37kg / 49kg
Amperage / Starting Amperage	5.09A / 22A
Electrical Consumption	(AT32°C / WT21°C) 804W
Refrigerant Charge	R404A/480g
Ice Storage Capacity	Maximum 144 kg
Ice Production per 24H	(AT10°C / WT10°C) Approx. 204 kg (AT21°C / WT15°C) Approx. 180 kg (AT32°C / WT21°C) Approx. 140 kg

Water Consumption per 24H	(AT32°C/WT21°C) 0.15m ³ (1.1 L / kg Ice)
Ice Production Freeze Cycle Time	(AT21°C/WT15°C) 14.3 min
Ice Production per Cycle	(AT21°C/WT15°C) Approx. 1.8kg / 220 pcs

OPERATING CONDITIONS

Voltage Range	198 - 242 V
Ambient Temperature	5 - 38°C
Water Supply	5 - 32°C
Water Supply Pressure	0.07 - 0.55 Mpa (0.7 - 5.5 bar)
Supply Voltage	1/220 - 240V / 50Hz



HOSHIZAKI

HOSHIZAKI (THAILAND) LIMITED

No. 99 CP Tower North Park building 9th Floor, Zone D1 Soi Ngamwongwan 47 Intersection 42, Thung Song Hong Subdistrict, Lak Si District, Bangkok 10210 Thailand. TEL +66 2 005 9980 | FAX +66 2 516 2646
<https://hoshizaki-sea.com>